



NBF618S

User Manual



6x8" ACTIVE ALUMINUM SUBWOOFER

YOUR SPEAKER

Dear Customer,

Congratulations on purchasing our Nakamichi product for your sound system.

This product has been designed and manufactured to Nakamichi's exacting standards to ensure many years of audio enjoyment. For the best performance, we recommend that you have your Nakamichi product installed by an authorized Nakamichi dealer.

If you would like to install this product on your own, we recommend for you to go through this manual to familiarize yourself with all the installation requirements and procedures.

If you encounter any issues or if you have any questions on the operation of this product, please contact your nearest authorized Nakamichi dealer for assistance, or you may also contact us through our website or social media channels.

Installation of Your Product

In today's modern vehicles, it is very easy to cause damage to existing systems through improper installation. Please follow and scrutinize all wiring diagrams to ensure that you have connected everything in its proper place.

If you find yourself uncomfortable or unfamiliar with understanding the wiring and installation diagrams or testing instructions, do contact your nearest Nakamichi dealer to perform the installation for you.

Safety Warnings and Considerations

- Clean only with a dry cloth or other similar materials.
- Install your product in a dry, well-ventilated location that does not interfere with your vehicle's safety equipment.
- Do not block any ventilation openings when installing this product.
- Do not mount the product in the engine compartment of your vehicle or in any areas of extreme heat such as mufflers, silencers, exhaust pipes or other heat producing apparatus.
- Securely mount the product so that it does not come loose in the event of a collision or as a result of repeated vibrations that might occur during normal operation.
- Installation of the apparatus must be done with great care to prevent damage to your vehicle's fuel lines, power, and other electrical wiring, hydraulic brake lines, and other systems. If possible, always visit your nearest Nakamichi dealer to perform the installation.
- Do not run any wiring outside or underneath the vehicle. Keep all wires inside the vehicle.
- Take the necessary precautions when making connections to the vehicle's battery to avoid any potential shock.

YOUR SPEAKER

- Protect all system wires from sharp edges by carefully routing them, always use rubber grommets to protect wiring and cables whenever you are installing them through metal openings.
- Secure all wiring using cable ties or wire clamps to protect them from moving parts and sharp edges.
- This apparatus shall not be exposed to dripping or splashing, and no object filled with liquids, shall be placed on the apparatus.
- Refer all servicing to qualified service personnel. Servicing is required when the apparatus has been damaged in any way, such as the power input terminals are damaged, liquid has been spilled or objects have fallen into the apparatus, the apparatus has been exposed to rain or moisture, does not operate normally, or has been dropped.
- Fuses shall be replaced only with the correct type and fuse value, and only when the apparatus is powered off.
- Exposure to high sound pressure levels may lead to permanent hearing loss. Take every precaution to protect your hearing.
- This product is designed specifically for use with 12 volt, negative- ground electrical systems only. Using this product in systems with positive ground and/or voltages other than 12V may result in damage to the product and your system.

ACCESSORY LIST

1. User Manual (One in English and Chinese)	2pcs
2. Mounting Screw Bag (Ø4x16mm x 4pcs, Ø4x6mm x 4pcs, Ø3x8mm x 2pcs,)	1pc
3. High Level Input Cable	1pc
4. Remote Control + Remote Cable	1set
5. Mounting Bracket	4pcs
6. Magic Tape (40x80mm)	2pcs
7. Fuse	1pc

SPECIFICATIONS

N-power	100W	Low pass filter	50Hz - 150Hz
Max power	1000W	Bass Boost	0 - 12dB
THD	<0.4%	Subsonic Fiter	20Hz (Fixed)
Signal-to-noise ratio	>90dB	Fuse rating	20 A
Frequency response	20Hz - 150Hz	Subwoofer	6x8" , 4Ω
Input sensitivity,high level	1V - 10V	Dimensions (L x W x H) mm	260 x 195x 73mm
Input sensitivity,low level	120mV - 4V		

PANEL CONTROLS AND FEATURES

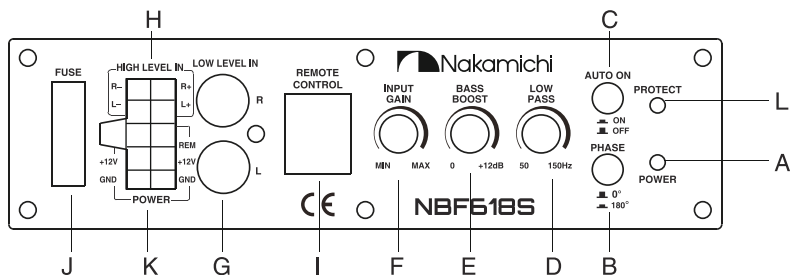

A. POWER STATUS LED

This LED glows green when power is on and no problems are present.

B. PHASE SHIFT

Use this switch to help compensate for time alignment problems in the system. Such problems usually result from having the subwoofer at a different distance from the listener than the other speakers in the system.

C. AUTO POWER ON

The AUTO POWER ON(ON/OFF) is for high level (speaker-level) connections. When the switch is in the "ON" position, the subwoofer will AUTO POWER ON when there is signal input. If the amplifier detected no signal input, the amplifier will auto turn off. If you prefer to use the remote turn on/off connection, the switch is in the OFF position.

Note: Please connect the remote terminal to the remote output of head unit as Fig.2 when you hear the unit turn ON/OFF POP noise from the subwoofer.

D. LOW PASS FILTER

This control permits you define the frequency range you want the subwoofer amplifier to receive. The subwoofer will reproduce all sound below the frequency you set.

Note: The low pass filter frequency can be higher or lower than the standard. There have +/-20% tolerance.

E. BASS BOOST

The BASS BOOST feature will increase the sound level in the bass frequencies.

F. INPUT GAIN CONTROL

After you have installed your system, turn this control to minimum.

Turn the head unit on (and the subwoofer will turn on via the remote connection). Turn the head unit volume to about 2/3 full level. Slowly turn up the subwoofer input gain control until you hear a small amount of distortion. Then reduce the level until the distortion is completely gone. Level the control at this setting.

G. LOW LEVEL RCA INPUTS

Low level inputs are the recommended way to introduce the audio signal to the subwoofer if RCA outputs are present on your head unit or other signal source (such as a sound processor).

H. HIGH LEVEL (SPEAKER LEVEL) INPUTS

If your head unit does not have RCA outputs you can use the speaker outputs for the audio source for the subwoofer. Use the supplied cable and wire harness and connect the outputs properly as shown in the connection diagram in this manual.

I. REMOTE LEVEL CONTROL PORT

Attach the included remote level control to control the volume level of the subwoofer independently.

J. FUSE

Do not use a fuse with a different value and never replace the fuse with a wire or coin.

K. POWER INPUT TERMINAL

L. PROTECT STAIUS LED

This LED glows red when protection circuits is comes on.

WIRING

LOW LEVEL INPUT WIRING

Low-level (RCA) input wiring is preferred for best audio performance. Most trunk and under-seat installations will require a 6-12 feet RCA cable. Always use a high quality cable.

NOTE: Do not connect both the high level and low level inputs from your receiver to your amplifier at the same time!

Fig.1

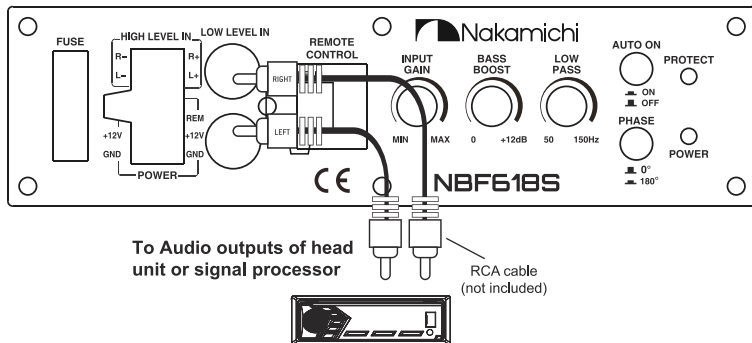
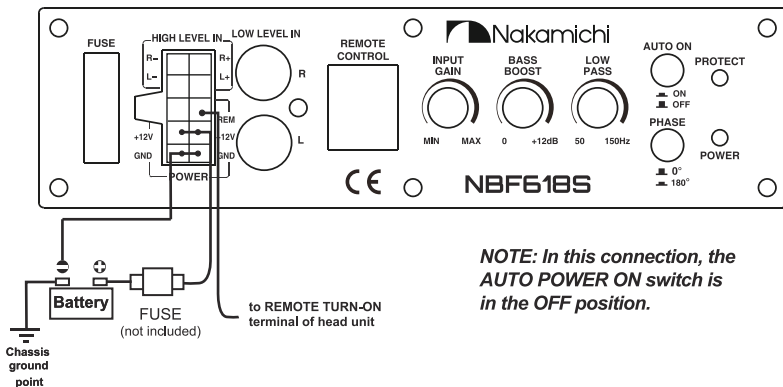

Fig.2



POWER CONNECTIONS

Connect the ground terminal to the closest point on the chassis of the vehicle. Use 8 gauge (or heavier) wire to connect the ground cable.

Connect the remote terminal to the remote output of head unit using 16 gauge (or heavier) wire.

Connect an empty fuse holder within 16" (40 cm) of the car battery, and run 8 gauge (or heavier) cable from this fuse to the amplifier location. Then connect the fuse holder to the "BATT+" (+12V) connection on the subwoofer rear panel.

WIRING

HIGH LEVEL INPUT WIRING

The high level input(s) should only be used when your receiver lacks RCA outputs. If the RCA outputs are not present, connect the speaker outputs from the receiver to the high level input connector of the amplifier. Be sure to observe polarity to avoid audio phase problems.

NOTE: Do not connect BOTH the high level and low level inputs from your receiver to your amplifier at the same time!

Fig.3

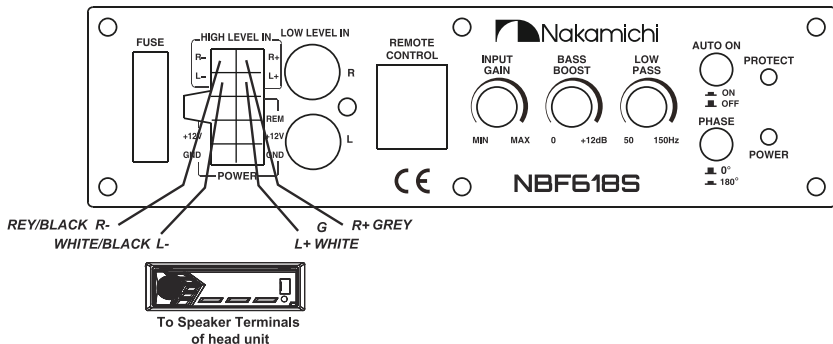
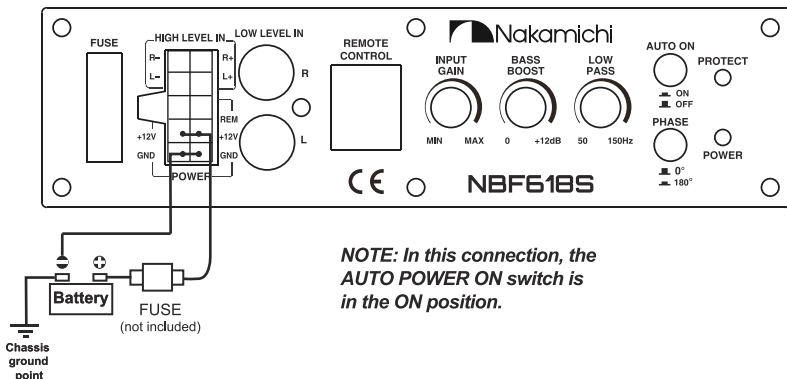
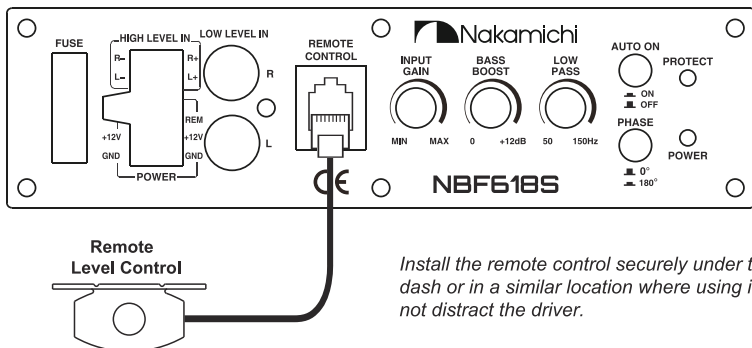

Fig.4



REMOTE LEVEL CONTROL CONNECTION

Fig.5



TROUBLESHOOTING

If you experience operation or performance problems with this product, compare your installation with the electrical wiring diagram on the previous pages. If problems persist, read the following troubleshooting tips which may help eliminate the problems.

SYMPTOM	POSSIBLE REMEDY
Products will not power up	<p>Check to make sure you have a good ground connection. Check that the Remote Input (Turn-on) has at least 5V DC. Check that there is battery power on the (+) terminal. Check that there is at least 12V. Check all fuse, replace if necessary. Make sure that the Protection LED is not illuminated. If it is lit shut off the amplifier briefly, and then repower it.</p>
Protection LED comes on when amplifier is powered up	<p>Turn down the volume control on the head unit to prevent overdriving. Check that there is good air circulation around the amp.</p>
No output	<p>Check that all fuses are OK. Check that unit is properly grounded, Check that the Remote Input (Turn-on) has at least 5V DC. Check that the RCA audio cables are plugged into the proper inputs.</p>
Low output	<p>Reset the Level Control. Check the Crossover Control settings.</p>
High hiss in the sound.	<p>Disconnect all RCA inputs to the power sub's control panel. If the hiss disappears, then plug in the component driving the amplifier and unplug its inputs. If the hiss disappears at this point, go on until the faulty/noisy component is found. It is best to set the amplifier's input level control as low as possible. The best subjective signal-to-noise ratio is achieved in this manner. Try to set the head unit as high as possible (without distortion).</p>
Squealing noise is present.	<p>Check for improperly grounded RCA interconnects.</p>
Distorted sound.	<p>Check that the Input Level Control is set to match the signal level of the head unit.</p>
Engine noise (static type)	<p>This is usually caused by poor quality RCA cables, which can pick up radiated noise. Use only the best quality cables, and route them away from power cables.</p>
Engine noise (alternator whine)	<p>Check that the RCA grounds are not shorted to the vehicle chassis. Check that the head unit is properly grounded.</p>



CONNECT WITH US ONLINE TO EXPLORE NAKAMICHI'S COMPLETE RANGE,
INSTRUCTIONS & SOFTWARE DOWNLOADS AND WARRANTY REGISTRATION.

WWW.NAKAMICHICARAUDIO.COM

 [nakamichi.global](https://www.facebook.com/nakamichi.global)

 [nakamichi.caraudio](https://www.instagram.com/nakamichi.caraudio)

Nakamichi Corp, Japan

Made in China | 中國製造